



#### Product Summary

$V_{(BR)DSS}$	$R_{DS(on)TYP}$	$I_D$
100V	46m $\Omega$ @10V	12A
	49m $\Omega$ @4.5V	

#### Feature

- Trench Technology Power MOSFET
- Low  $R_{DS(on)}$
- Low Gate Charge
- Low Gate Resistance

#### Application

- DC/DC Converter
- High-Frequency Switch

#### MARKING:



M460ND10L= Device  
Code XX = Date Code  
Solid Dot = Pin1 Indicator

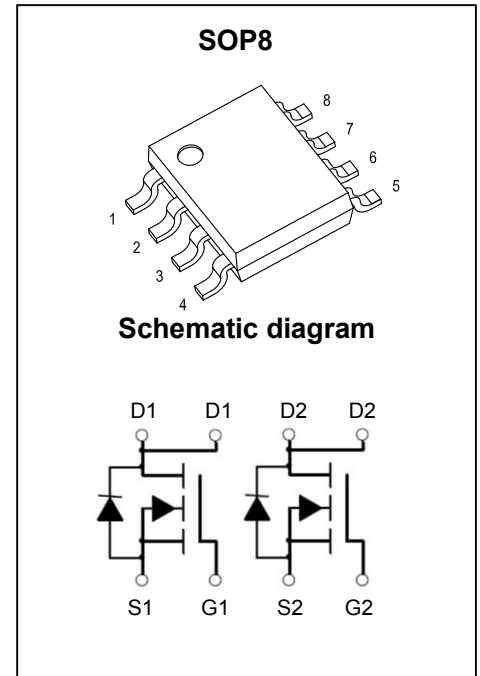

#### ABSOLUTE MAXIMUM RATINGS ( $T_A = 25^\circ\text{C}$ unless otherwise noted)

Parameter	Symbol	Value	Unit
Drain - Source Voltage	$V_{DS}$	100	V
Gate - Source Voltage	$V_{GS}$	$\pm 20$	V
Continuous Drain Current <sup>1</sup>	$I_D$	12	A
$T_C = 25^\circ\text{C}$			
Pulsed Drain Current <sup>2</sup>	$I_{DM}$	80	A
Single Pulsed Avalanche Current <sup>3</sup>	$I_{AS}$	16	A
Single Pulsed Avalanche Energy <sup>3</sup>	$E_{AS}$	80	mJ
Power Dissipation <sup>5</sup>	$P_D$	21	W
$T_C = 25^\circ\text{C}$			
Thermal Resistance from Junction to Ambient <sup>6</sup>	$R_{\theta JA}$	58	$^\circ\text{C/W}$
Thermal Resistance from Junction to Case	$R_{\theta JC}$	5.9	$^\circ\text{C/W}$
Junction Temperature	$T_J$	150	$^\circ\text{C}$
Storage Temperature	$T_{STG}$	-55~ +150	$^\circ\text{C}$

## MOSFET ELECTRICAL CHARACTERISTICS ( $T_J = 25^\circ\text{C}$ unless otherwise noted)

Parameter	Symbol	Test Condition	Min	Type	Max	Unit
<b>Off Characteristics</b>						
Drain - Source Breakdown Voltage	$V_{(BR)DSS}$	$V_{GS} = 0V, I_D = 250\mu A$	100			V
Zero Gate Voltage Drain Current	$I_{DSS}$	$V_{DS} = 80V, V_{GS} = 0V$			1	$\mu A$
Gate - Body Leakage Current	$I_{GSS}$	$V_{GS} = \pm 20V, V_{DS} = 0V$			$\pm 100$	nA
<b>On Characteristics<sup>4</sup></b>						
Gate Threshold Voltage	$V_{GS(th)}$	$V_{DS} = V_{GS}, I_D = 250\mu A$	1.0	2.0	3.0	V
Drain-Source On-Resistance	$R_{DS(on)}$	$V_{GS} = 10V, I_D = 4A$		46	56	$m\Omega$
		$V_{GS} = 4.5V, I_D = 4A$		49	69	$m\Omega$
Forward Transconductance	$g_{FS}$	$V_{DS} = 5V, I_D = 4A$	10			S
<b>Dynamic Characteristics</b>						
Input Capacitance	$C_{iss}$	$V_{DS} = 45V, V_{GS} = 0V, f = 1MHz$		3026		pF
Output Capacitance	$C_{oss}$			62		
Reverse Transfer Capacitance	$C_{rss}$			51		
Gate Resistance	$R_g$	$V_{DS} = 0V, V_{GS} = 0V, f = 1MHz$		1.4		$\Omega$
<b>Switching Characteristics</b>						
Total Gate Charge	$Q_g$	$V_{DS} = 50V, V_{GS} = 10V, I_D = 15A$		54.5		nC
Gate-Source Charge	$Q_{gs}$			8.0		
Gate-Drain Charge	$Q_{gd}$			12.1		
Turn-On Delay Time	$t_{d(on)}$	$V_{DD} = 50V, V_{GS} = 4.5V, R_L = 5\Omega$ $R_G = 3\Omega$		7.5		ns
Turn-On Rise Time	$t_r$			3.5		
Turn-Off Delay Time	$t_{d(off)}$			23		
Turn-Off Fall Time	$t_f$			5.5		
<b>Source - Drain Diode Characteristics</b>						
Diode Forward Voltage <sup>4</sup>	$V_{SD}$	$V_{GS} = 0V, I_S = 4A$			1.2	V

Notes :

- 1.The maximum current rating is limited by package.And device mounted on a large heatsink
- 2.Pulse Test : Pulse Width  $\leq 10\mu s$ , duty cycle  $\leq 1\%$ .
- 3.EAS condition:  $V_{DD} = 50V, V_{GS} = 10V, L = 0.5mH, R_G = 25\Omega$  Starting  $T_J = 25^\circ\text{C}$ .
- 4.Pulse Test : Pulse Width  $\leq 300\mu s$ , duty cycle  $\leq 2\%$ .
- 5.The power dissipation  $P_D$  is limited by  $T_{J(MAX)} = 150^\circ\text{C}$ .And device mounted on a large heatsink
- 6.Device mounted on  $1in^2$  FR-4 board with 2oz. Copper, in a still air environment with  $T_A = 25^\circ\text{C}$ .

## Typical Characteristics

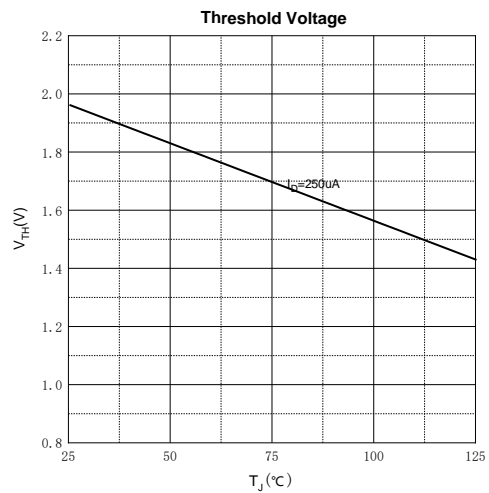
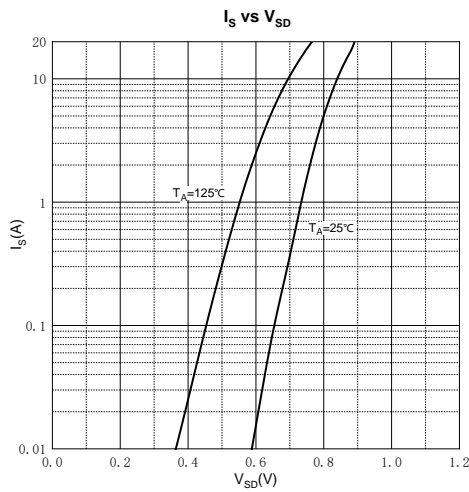
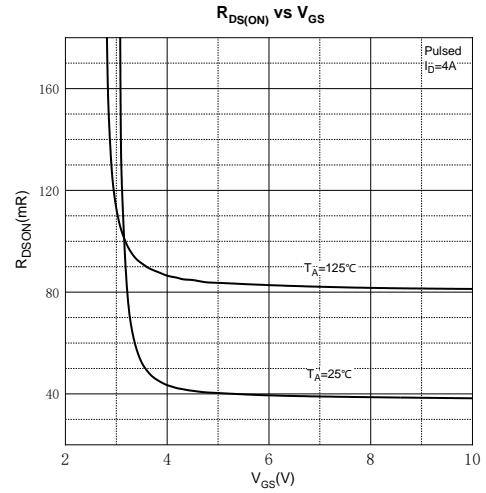
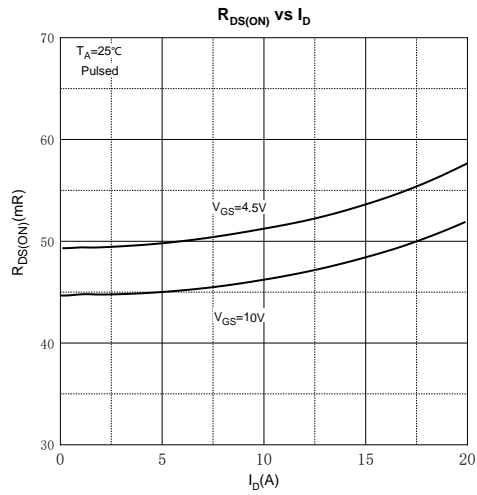
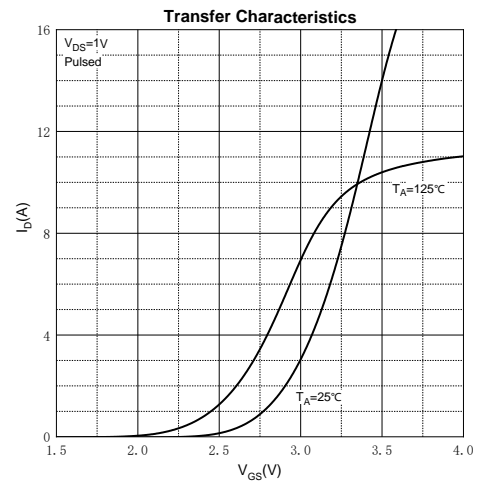
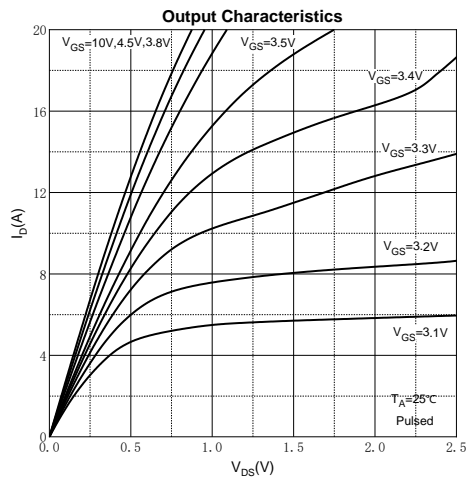

## SOP8 Package Information

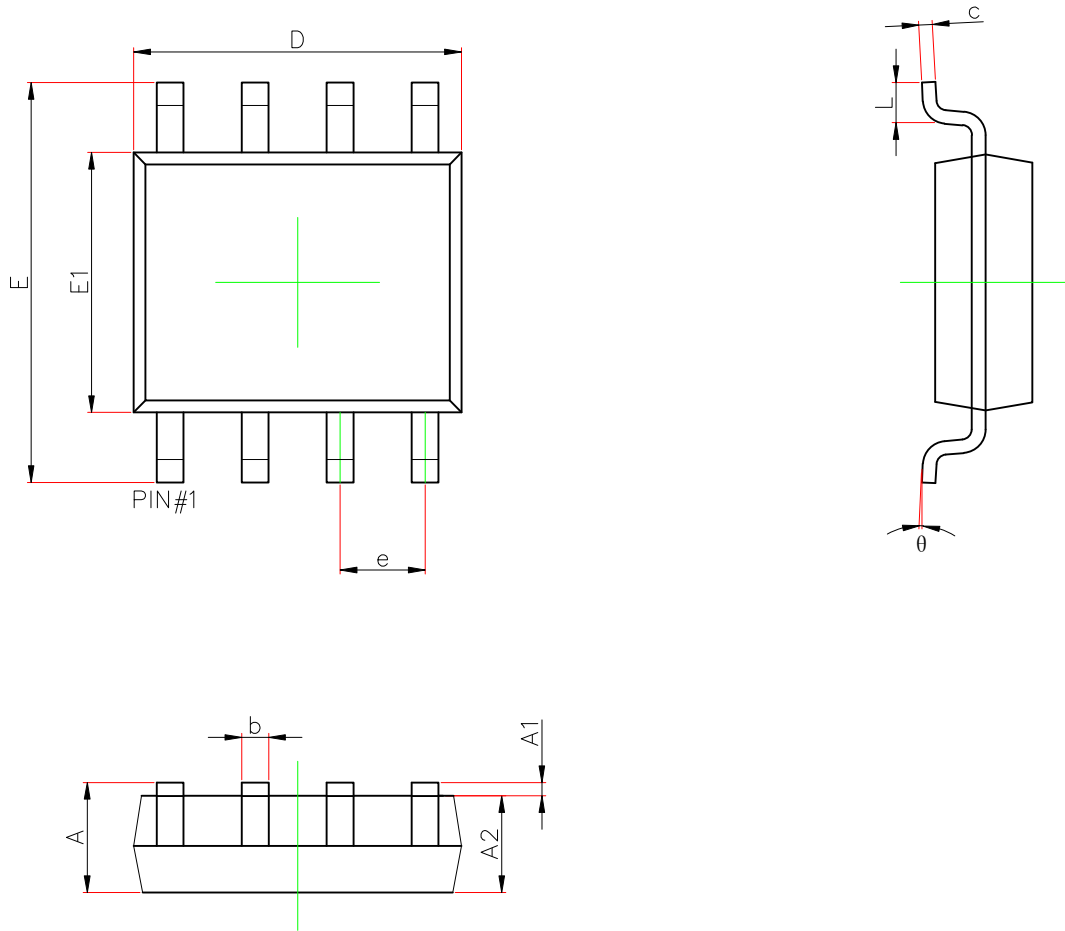

Symbol	Dimensions In Millimeters		Dimensions In Inches	
	Min.	Max.	Min.	Max.
A	1.350	1.750	0.053	0.069
A1	0.100	0.250	0.004	0.010
A2	1.350	1.550	0.053	0.061
b	0.330	0.510	0.013	0.020
c	0.156	0.250	0.006	0.010
D	4.700	5.100	0.185	0.201
e	1.270(BSC)		0.050(BSC)	
E	5.800	6.200	0.228	0.244
E1	3.700	4.100	0.146	0.161
L	0.400	1.270	0.016	0.05
$\theta$	0°	8°	0°	8°

**Attention:**

- GreenPower Electronics reserves the right to improve product design function and reliability without notice.
- Any and all semiconductor products have certain probability to fail or malfunction, which may result in personal injury, death or property damage. Customer are solely responsible for providing adequate safe measures when design their systems.
- GreenPower Electronics products belong to consumer electronics or other civilian electronic products.